

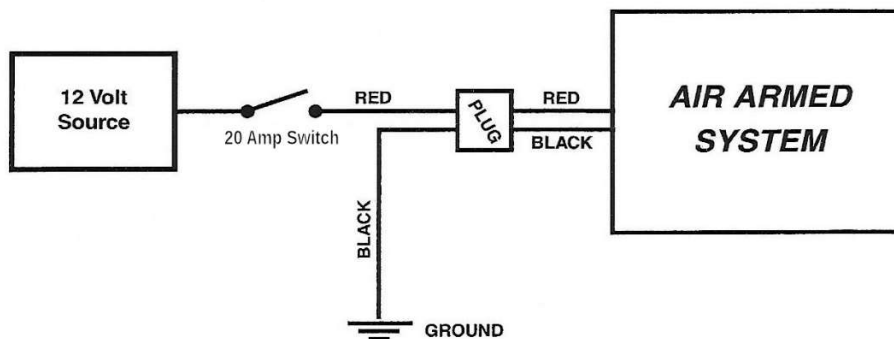

## Instructions

### DRAIN AFTER EVERY RACE WEEKEND

- Find a flat surface to mount unit. Unit must be mounted in a flat horizontal position.
- We recommend NOT to mount unit in driver compartment. Dragster applications typically in front of the foot box and door cars typically in the trunk.
- Mark the four holes where the vibration dampeners mount on the bottom plate and drill the mounting location on the car with a 5/16 drill bit.
- Use ¼" air line as the main feed line and insert into the ¼" compression fitting on the side of the regulator.
- Connect the red wire to a 12-volt source (minimum 20 amp capable) and connect the black wire to a good chassis ground.
- Turn on the compressor unit and let it run until the pump cycles off.
- Check complete air system in car for leaks.
- The regulator is set and tested at 90 psi. After installation in vehicle, check to make sure the system is set to 90 psi.



K&R Performance Engineering  
4252 Spring Place Rd. SE  
Cleveland, TN 37323  
Phone: 423-614-7778